

# DEMAND **MORE** STOPPING POWER



## AIR DISC BRAKES

Our demand for more stopping power results in **air disc brakes** that meet and exceed customer specifications. We have the same goal as fleet owners and operators, to reduce maintenance and extend service intervals. With over 30 years of suspension expertise, dependability is priority one.

- Helps to reduce brake fade
- Greater downhill performance
- Symmetrically balanced left and right brake power
- Brake pad changes and adjustments are quicker



For more information, call 800.445.0736



# AIR DISC BRAKES

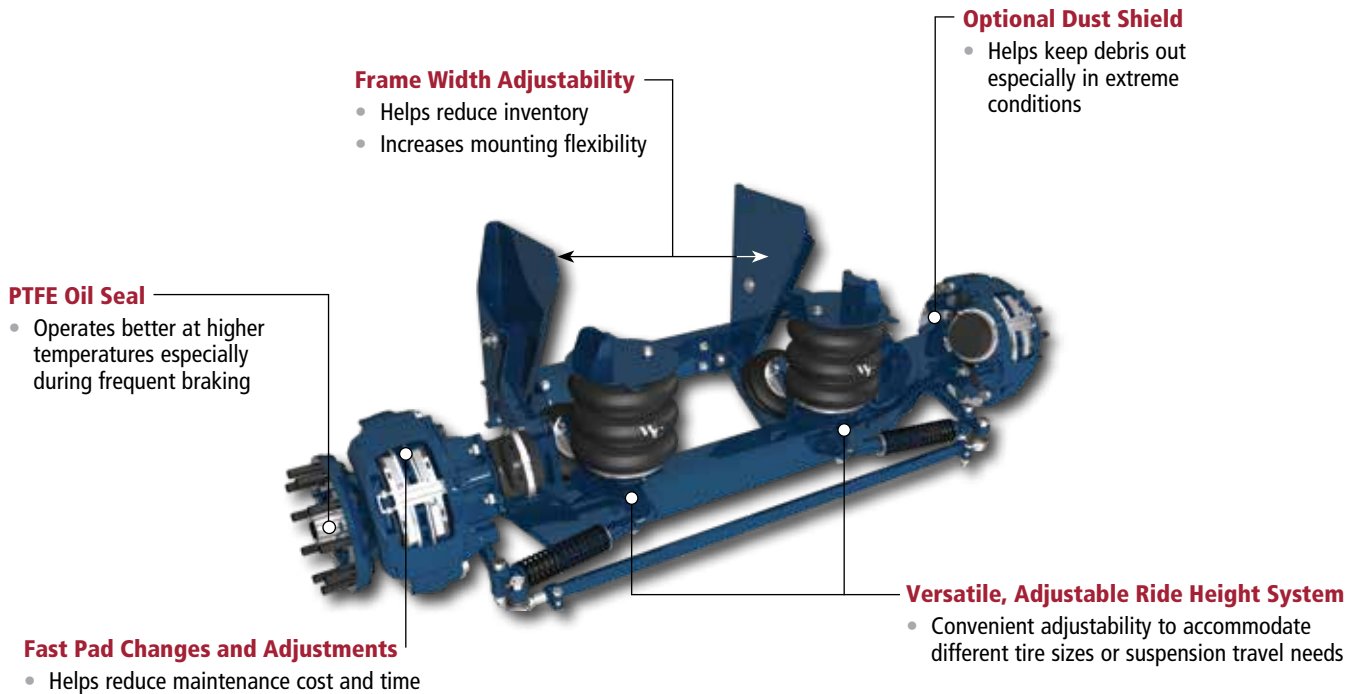

SL13 MODEL			
<b>Weight</b>	971 lbs.	<b>ABS Sensor</b>	Yes (Optional)
<b>Capacity</b>	Up to 13.5K	<b>Dust Shield</b>	Yes (Optional)
<b>Package</b>	22.69 inches (With ADB)	<b>Wheel Size</b>	22.5 inches
<b>Kingpin Kit</b>	Westport	<b>Lining</b>	BX-275
<b>Bushing Kit</b>	SRK1190-1	<b>Chamber</b>	T-14 and T-16
<b>Load Air Spring</b>	AS0048-3C	<b>Hub</b>	Hub Piloted
<b>Lift Air Spring</b>	AS0058C	<b>Spindle</b>	FF
—	—	<b>Bearings</b>	Currently only offer Conmet Preset Plus hub rotors for ADB

**Important reminder:** It is important to specify brake caliper position; certain applications require selection of specific wheel and valve stem products; trailer configurations require specific dolly applications.

*Actual product performance may vary depending upon vehicle configuration, operation, service and other factors.  
All applications must comply with applicable specifications from W&C and the respective vehicle manufacturer.  
Contact W&C for additional details regarding specifications, applications, capacities, and operation, service and maintenance instructions.*

Contact W&C at 972.547.6020 for additional information.



**W&C**  
725 E. University Drive, McKinney, Texas 75069  
972.547.6020 • 800.445.0736 • Fax 972.542.0097  
[www.wcsuspensions-intl.com](http://www.wcsuspensions-intl.com)

